

## SE 200 | MEC Line Engineering mechanics



## Didactic concept for experiments in statics and strength of materials

- smart, communication-enabled components
- wireless digital connection

# Table of contents

Didactics and methodology	04
Smart data flow	06
Structure of the MEC Line	08
Smart components	10
Accessories	12
SE 200.01 MEC – Forces in trusses	14
SE 200.02 MEC – Forces on a suspension bridge	16
SE 200.04 MEC – Friction on the inclined plane	18
SE 200.05 MEC – Cable forces and pulley blocks	20
SE 200.07 MEC –Gerber beam	22
SE 200.08 MEC –Buckling	24
GUNT Science Media Center	26



Custom GUNT software with content adapted to the individual experiments enables real-time display and analysis.



The GUNT Science Media Center provides technical descriptions, manuals, exercises, videos and E-Learning courses with fundamental knowledge, theory and calculations for all experiments.

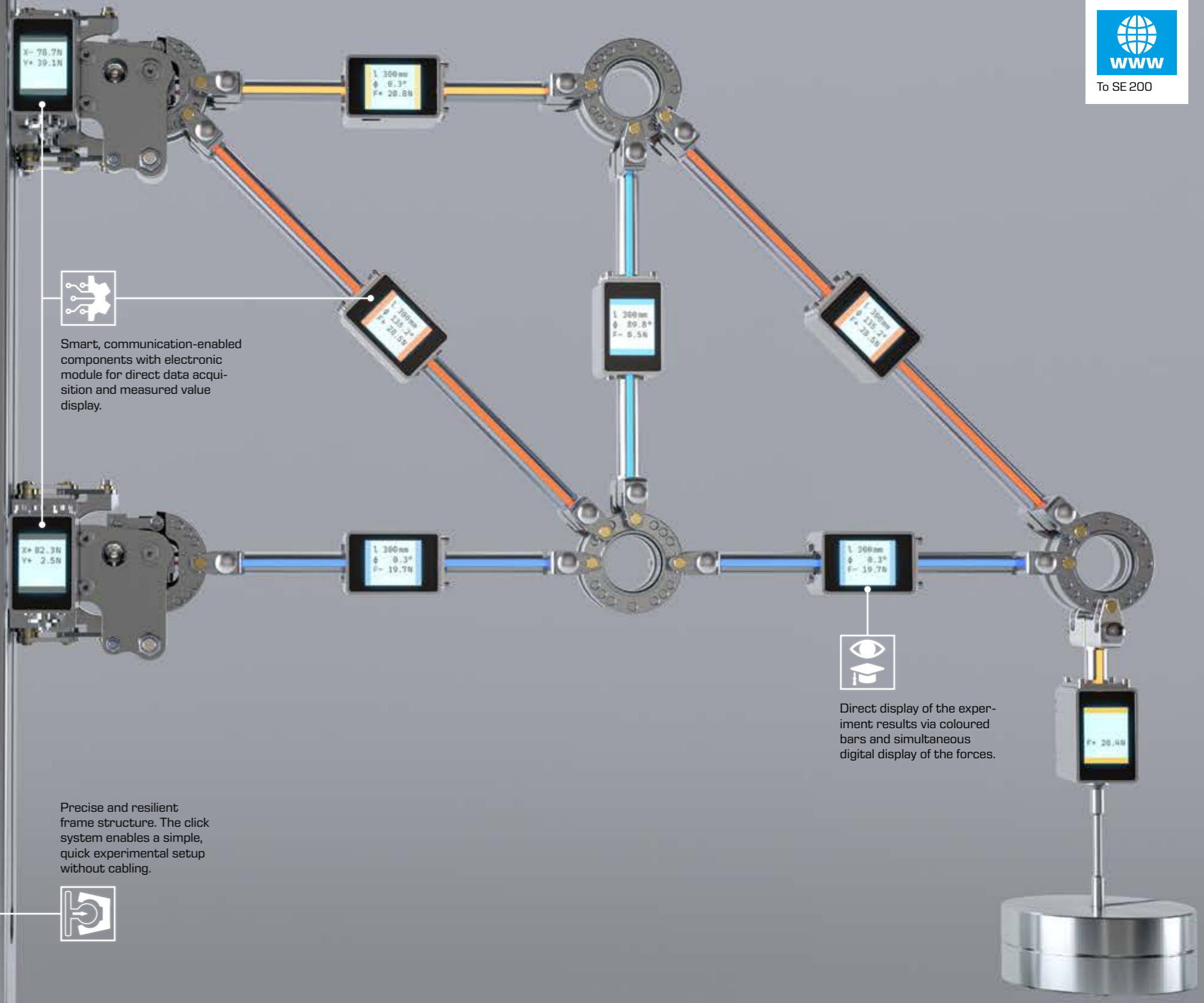
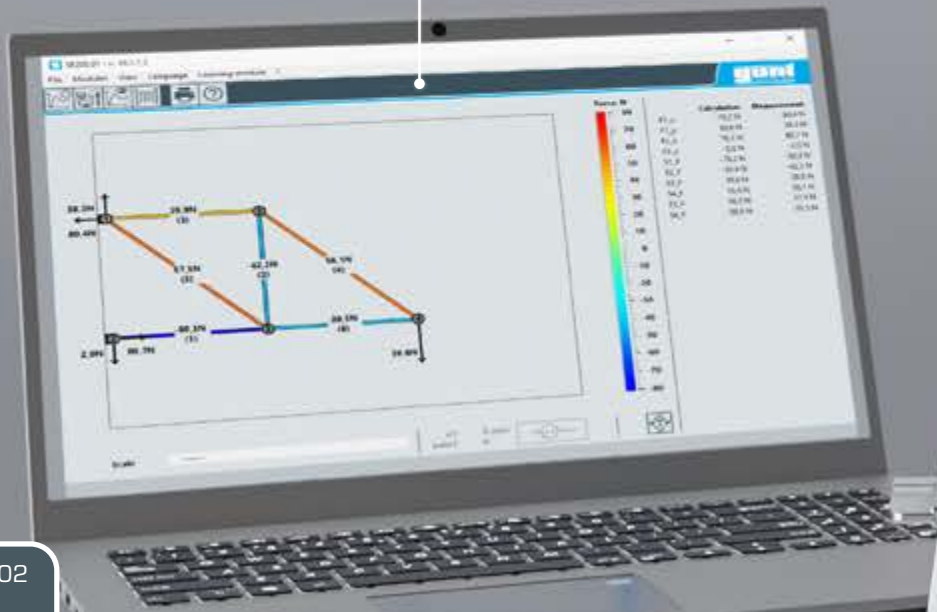

Smart, communication-enabled components with electronic module for direct data acquisition and measured value display.



Direct display of the experiment results via coloured bars and simultaneous digital display of the forces.



Precise and resilient frame structure. The click system enables a simple, quick experimental setup without cabling.



To SE 200

# Didactics and methodology

Experiments using all the senses – for an in-depth learning experience

## Develop the fundamentals of engineering mechanics according to textbook and curriculum in experiments

### What

- static systems in equilibrium of forces
- trusses: internal reaction and support reaction under external loads
- elastic reactions under external loads
- analysis of typical elements from civil engineering: beams, bridges
- familiarisation with stability problems

## Familiarisation with digital concepts and methods of measurement technology and data processing simultaneously

### How

- implement theoretical teaching topics in experiments by planning series of experiments and setting up your own experiments
- technically realise terms such as fixation or articulated support
- coloured display of forces, display of the loading as well as automatic topology transmission for direct feedback
- microprocessor-based measurement technology for force and angle, distance, position and identification
- application of Gray codes (reflected binary, RB)
- integration of FEM models, strength verification, etc.



### Haptic experience

- promotes the comprehension and internalisation of learning content through the sense of touch
- manual work and skill in setting up experiments
- no disruptive cabling of the individual elements
- sturdy components with click system, quick and easy to assemble



### Experimental learning

- promotes self-directed learning and effective teamwork
- accessories of the series can be combined in a modular way for setup and extension of the experiments
- possibility to create your own experiments with many variations



### Visual comprehension

- promotes abstraction skills
- visual representation of experimental processes that are otherwise invisible and can only be understood through calculation

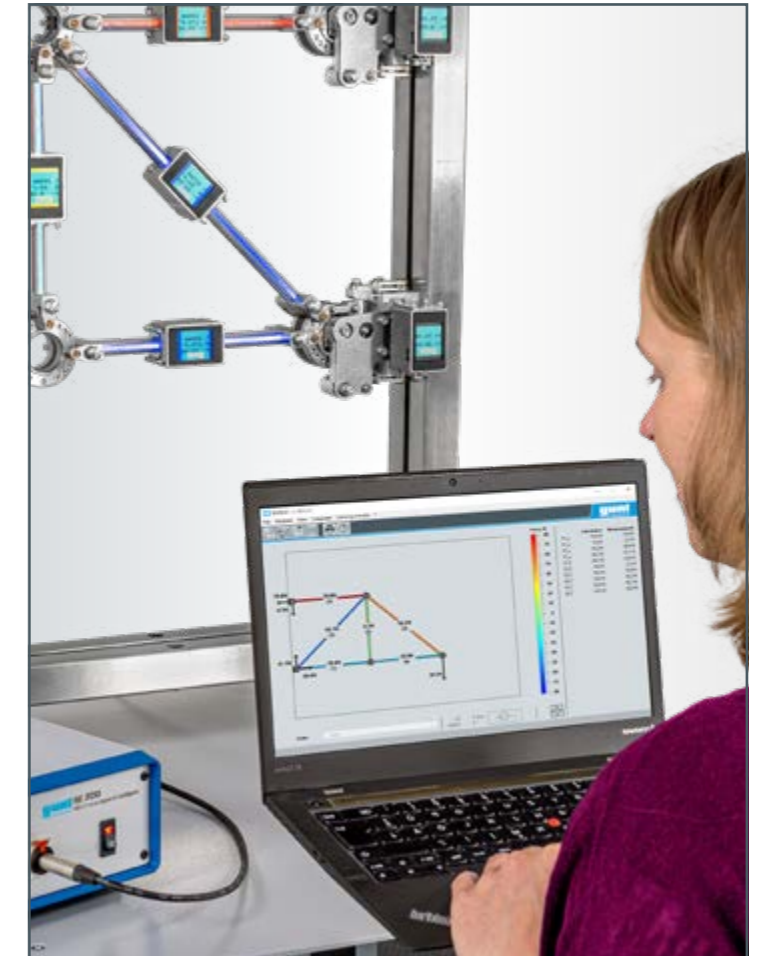

### Logical thinking

- promotes the recognition of interrelationships through the transmission of topology
- analysis of measurement results and estimation of errors



# Smart data flow – wireless information and power supply

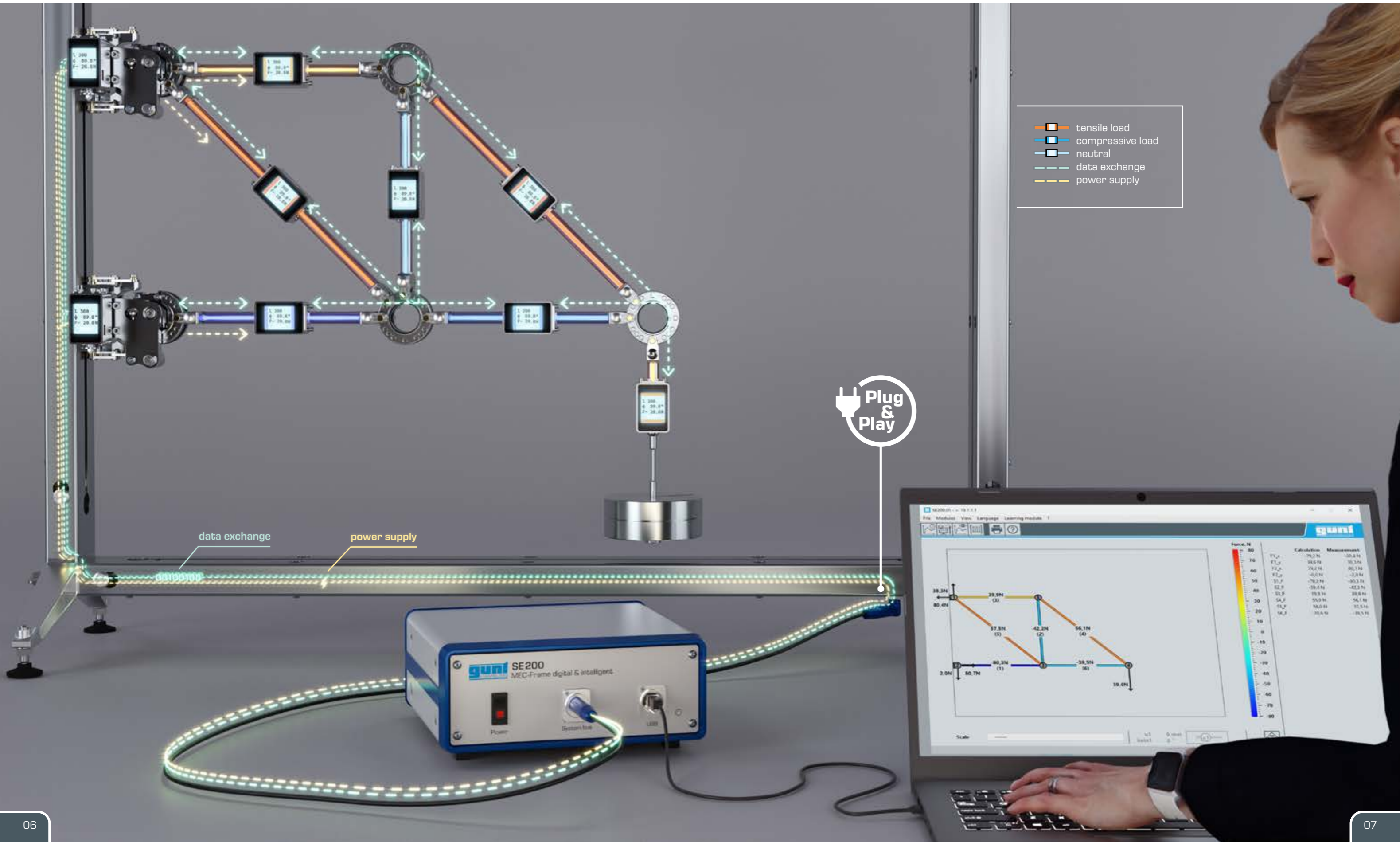

# Structure of the MEC Line

Full experimental setups are created from the mounting frame and the components for experiments, setup and measurement technology. The experiments are accompanied by software for real-time visualisation, measurement data acquisition and analysis.

## MEC – Frame: digital & smart

Mounting frame to hold smart, communication-enabled components with a master module for digital connection and measurement data acquisition



To SE 200

## Components for experiments in statics and strength of materials as accessories

- smart, communication-enabled bars with electronic module
- bridge components and beams
- pulley blocks, etc.

All components for the experiments including GUNT software

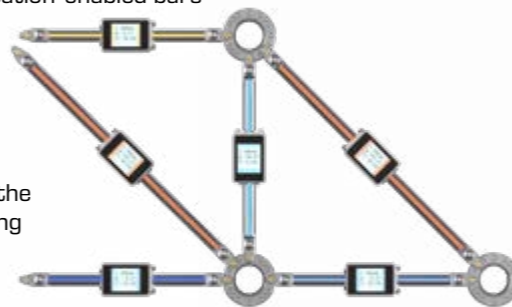

## Components for the setup and measurement technology as accessories

Smart, communication-enabled loads, supports, distance measurement etc. equipped with an electronic module for data acquisition and measured value display



Access to the GUNT Science Media Center

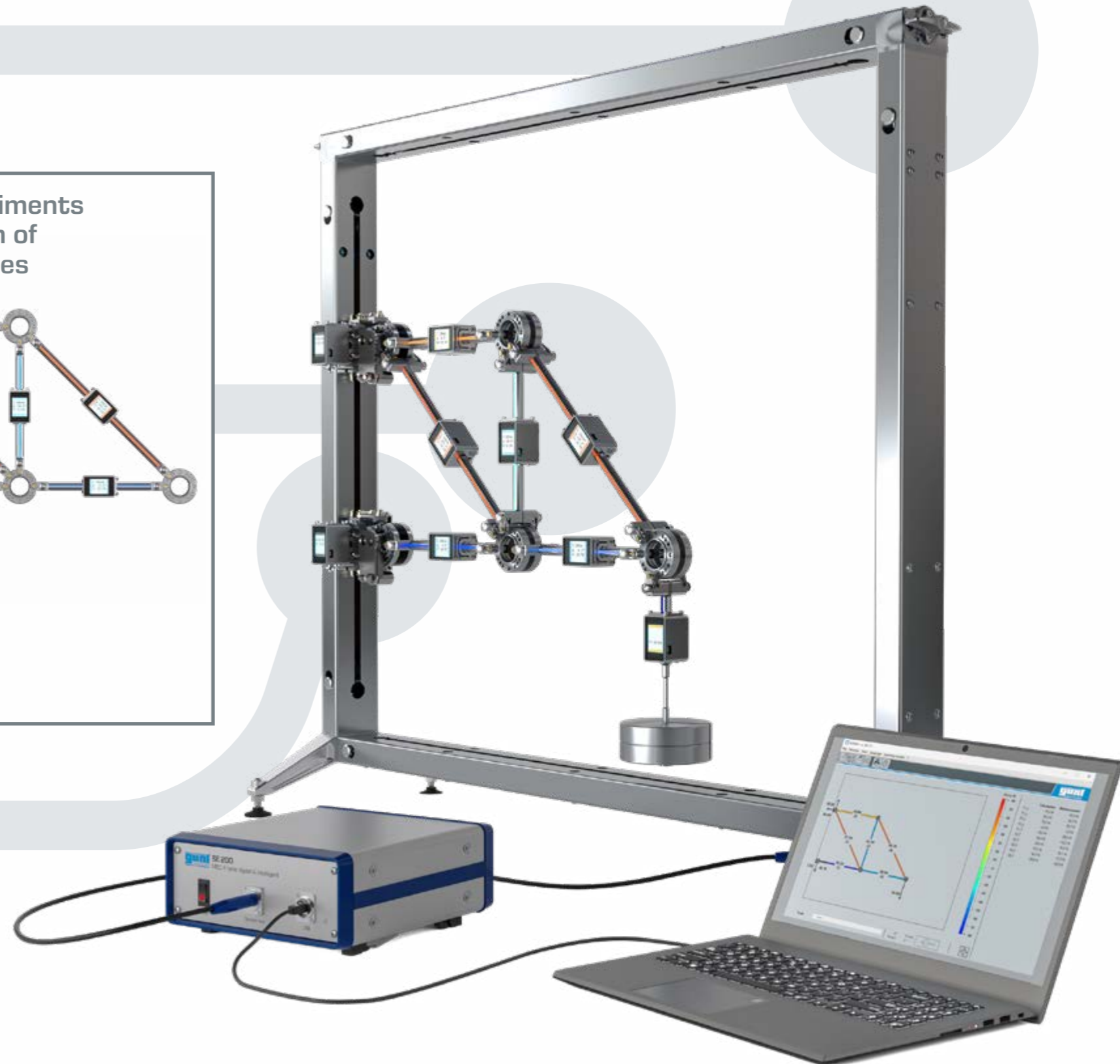

# Smart, communication-enabled components for the setup and measurement technology

## Components for the setup



**Mounting frame**

- base element for setting up versatile experiments
- click system for easy setup and reconfiguration, no tools required
- stainless steel hollow sections with integrated electrical cable
- defined snap-in points for exact topology determination and transmission



**Support**

- fixed support for connecting smart, communication-enabled components via click system
- horizontal or vertical installation at different positions in the mounting frame
- automatic detection of the installation position and dynamic adjustment in the GUNT software

**Electronic module**

- equipped with planar beam load cells for direct force measurement in x, y direction
- integrated acceleration sensor for angle measurement for correct display of the geometry

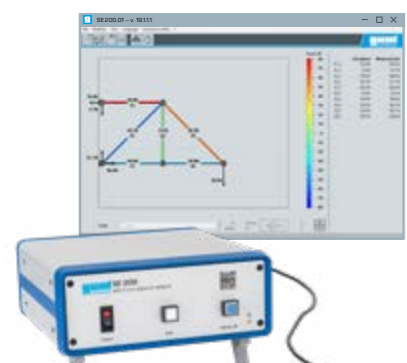

**Master module and software**

- master module detects all data from the electronic modules and transmits it to the GUNT software via USB
- automatic identification of the smart, communication-enabled components including position and alignment
- master module connected via Plug&Play and only 1 power BUS line



**Bar**

- tool-free setup and reconfiguration of various trusses without cabling
- force displayed as a measured value and as coloured illumination directly on the bar
- bars with articulated connection to node disks; loading only on compression or tension

**Electronic module**

- equipped with planar beam load cell for direct force measurement in the x direction
- communication in both bar directions to determine topology
- integrated acceleration sensor for angle measurement for correct display of the geometry

## Components for measurement technology

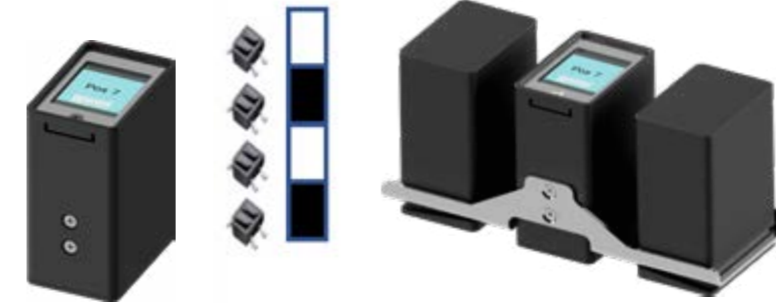

**Load**

- generation of weight forces through concentrated load
- generation of line loads by combining several load elements
- **electronic module** with Gray code reader for position detection and transmission to the GUNT software

**Line load**



**Vertical load**

- various weights included in delivery
- visual representation of the force as coloured illumination
- **electronic module** contains Planar Beam load cell for direct force measurement; transfer of position using topology

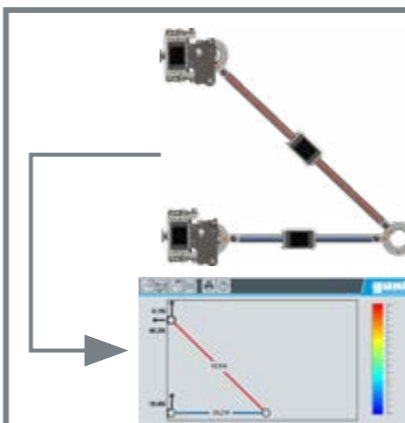

**Topology**

- real-time transmission of the topology to the geometry display in the GUNT software
- exact visualisation of the experiments during setup
- special algorithm for topology transmission, developed by GUNT



**Distance measurement**











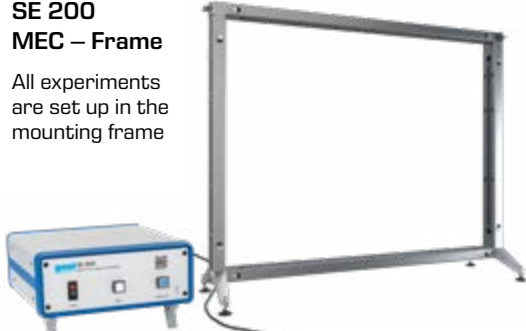





- articulated arm with long reach
- **electronic module** contains linear potentiometer for detecting paths and an acceleration sensor for detecting the measuring direction

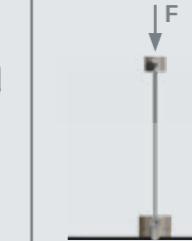
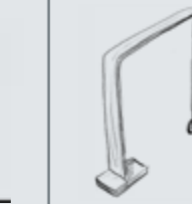

**Load unit**

- stepless generation of tensile and compressive forces in any direction
- visual representation of force
- **electronic module** contains Planar Beam load cell for direct force measurement and an acceleration sensor to detect the measuring direction

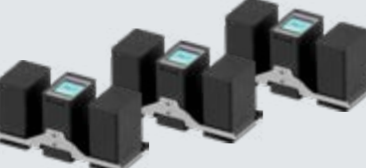
# Accessories

<p><b>SE 200</b> <b>MEC – Frame</b></p> <p>All experiments are set up in the mounting frame</p> 	<p><b>SE 200.01</b> <b>Forces in trusses</b></p> 	<p><b>SE 200.02</b> <b>Forces on a suspension bridge</b></p> 	<p><b>SE 200.03</b> <b>Parabolic arch bridge</b></p> 	<p><b>SE 200.04</b> <b>Friction on the inclined plane</b></p> 	<p><b>SE 200.05</b> <b>Cable forces and pulley blocks</b></p> 	<p><b>SE 200.06</b> <b>Three-hinged arch</b></p> 	<p><b>SE 200.07</b> <b>Gerber beam</b></p> 	<p><b>SE 200.08</b> <b>Buckling</b></p> 	<p><b>SE 200.09</b> <b>Deformation of frames</b></p> 	<p><b>SE 200.10</b> <b>Torsion of bars</b></p> 
<p><b>SE 200.21</b> <b>Support</b></p> 	2	2	2	–	min. 1 max. 2	2	2	1	2	–
<p><b>SE 200.22</b> <b>Load unit</b></p> 	max. 2	–	–	–	–	–	–	1	1	–
<p><b>SE 200.23</b> <b>Distance measurement</b></p> 	max. 1	–	max. 1	–	–	–	–	1	1	–
<p><b>SE 200.24</b> <b>Vertical load</b></p> 	min. 1 max. 2	–	max. 1	–	min. 1 max. 2	max. 1	max. 1	–	1	–
<p><b>SE 200.25</b> <b>Load</b> (Set of 5)</p> 	–	min. 1 max. 2	min. 1 max. 2	–	–	min. 1 max. 2	min. 1 max. 2	–	–	–
<p><b>SE 200.26</b> <b>Line load</b> (Set of 3)</p> 	–	max. 1	max. 1	–	–	max. 1	max. 1	–	–	–
<p><b>SE 200.27</b> <b>Bar set</b></p> 	any quantity	–	–	–	–	–	–	–	–	–

# SE 200.01 MEC – Forces in trusses

- smart, communication-enabled bars with electronic modules for data acquisition and measured value display
- setup of various trusses without cabling
- automatic identification and assignment of the bars in the GUNT software
- measured values and coloured display of the force directly on the bar
- calculated displacement of the truss can be magnified in the software



**Learning objectives**

- measurement of the bar forces in a statically determinate and statically indeterminate plane truss
- dependence of bar forces on the external force
- comparison of measurement results with mathematical solution methods
- basic principle: using strain gauge technology to measure forces

## Exercises

- 1 Setup of any truss with at least 6 bars and 1 load
  - exact recording of the geometry with real-time transmission to the GUNT software
  - measured values displayed directly on the bar, can be hidden if required

- 2 Calculation of external forces: loading by load, reaction of the supports

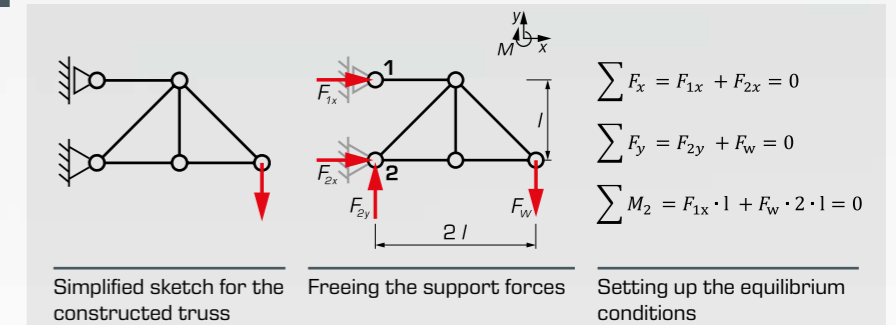

- 3 Calculation of internal forces: select and apply method of joints or Ritter's method of sections

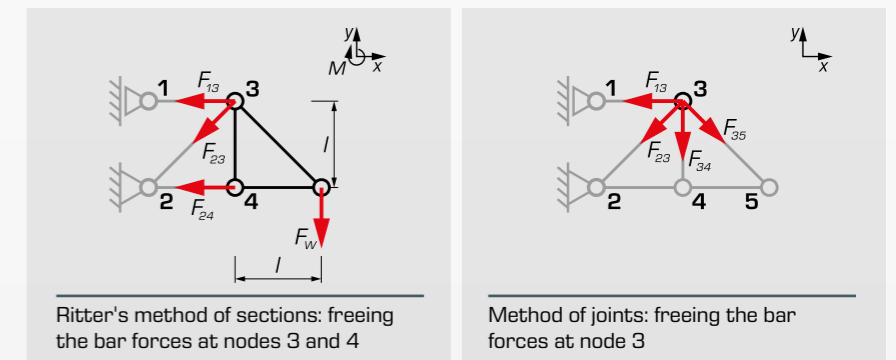

- 4 Checking the calculation: comparison of results with measured values and results in the GUNT software

Forces displayed in colour and measured values displayed in matrix form

287.3	-70.2	0	0	-107.1	70.2	0	-15.8
-70.2	19.9	0	0	70.2	-19.9	0	8.9
0	0	217.5	84.2	-112.1	-84.2	0	31.4
0	0	84.2	217.5	-84.2	-217.5	0	11.7
-141.1	70.2	-112.1	84.2	104.2	16.1	0	0
70.2	-19.9	-84.2	217.5	0	0	0	-28.1

# SE 200.02 MEC – Forces on a suspension bridge

## Exercises

- 1 Setup of a suspension bridge with rigid roadway and no additional loading

  - exact recording of the geometry with real-time transmission to the GUNT software
  - measured values displayed directly on the supports, can be hidden if required software

- 2 Calculation of external and internal forces without additional loading

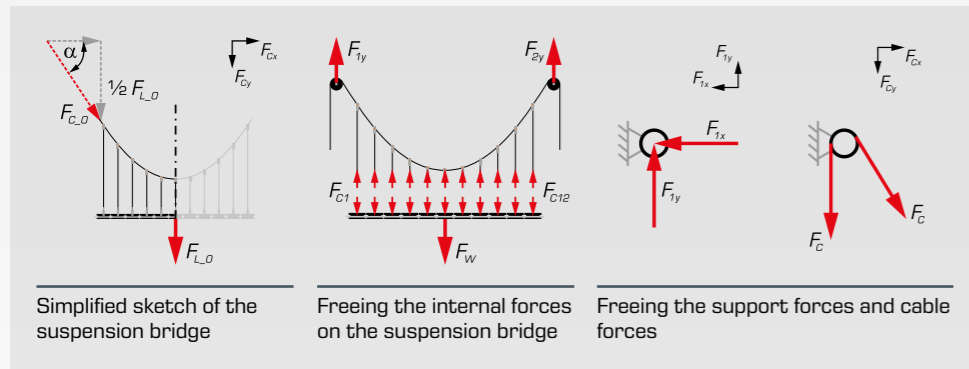

- 3 Calculation of external and internal forces with additional loading by single load, line load or moving load

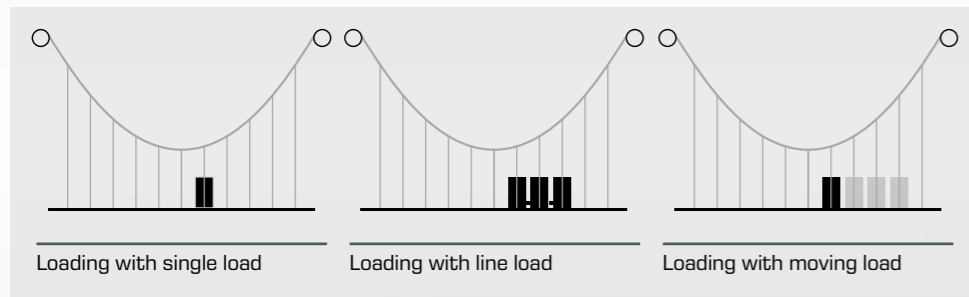

- 4 Checking the calculation: comparison of results with measured values at load/supports and the results from the GUNT software

Recording the measured values when loading with moving load

- setup of a suspension bridge together with smart, communication-enabled accessories
- experiments with rigid or flexible roadway
- automatic identification and assignment of the loads in the GUNT software



**Learning objectives**

- measurement of suspension cables forces on
  - ▶ unloaded suspension bridge
  - ▶ loaded suspension bridge
- measurement of the support forces as a function of the loading on the suspension bridge
- behaviour of a suspension bridge with rigid or flexible roadway
- investigation of line loads
- effect of a moving load

# SE 200.04 MEC – Friction on the inclined plane

- experiments with different material pairings
- angle of the inclined plane manually adjustable
- slow experiment sequence by using two different flywheels
- display of the measured values for angle, force and distance travelled directly on the inclined plane and in the GUNT software

## Exercise

- 1 Setup of an inclined plane on which a friction body is set in motion. Investigation of the acting forces and measurement of the coefficients for adhesion and friction.

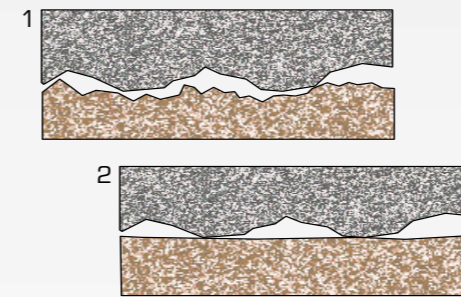

Investigation of surface roughness:  
 1 two solid bodies, both with high surface roughness  
 2 one solid body with high surface roughness and one body with low surface roughness

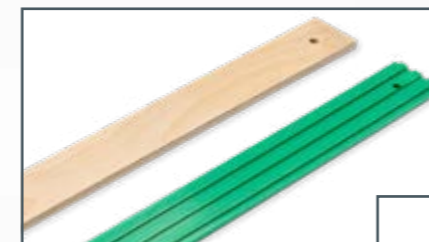

Different materials and surfaces for the inclined plane

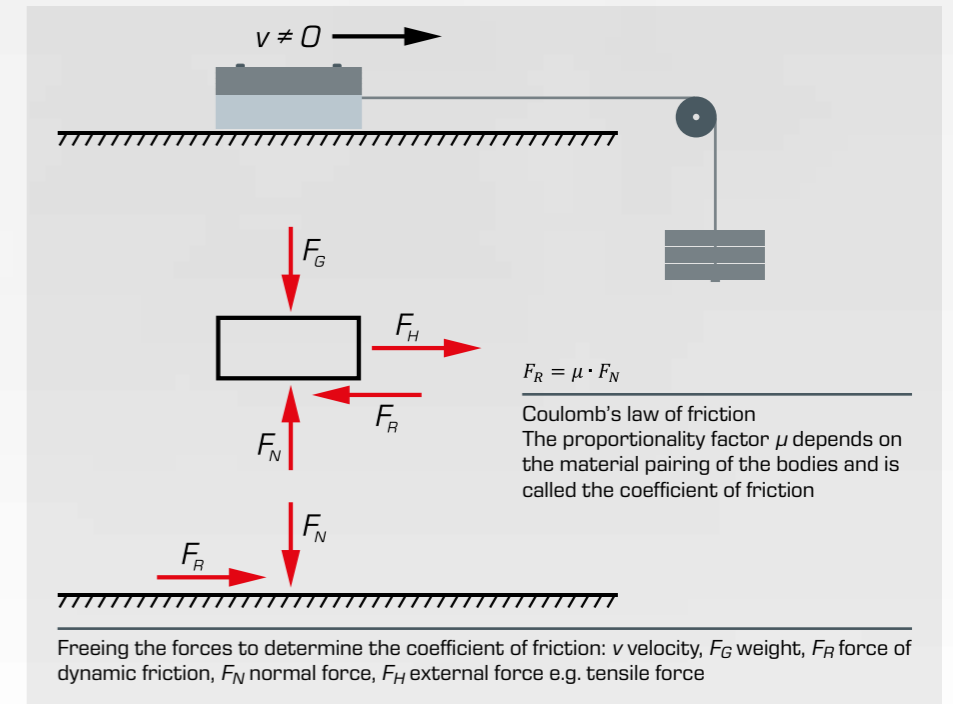

Two friction bodies:  
 1x with wheels, 1x without wheels



Variable loads for loading the friction body



GUNT software: forces and inclination angles, selection of the friction surface and flywheels

## Learning objectives

- measurement of the static and dynamic friction coefficient on an inclined plane
- determination of angular dependence and material dependence
- measurement of distance travelled and time
- determination of velocity and acceleration

# SE 200.05 MEC – Cable forces and pulley blocks

## Exercises

1 Setup of a four-cable pulley block with at least one loose and one fixed pulley

- exact recording of the geometry with real-time transmission to the GUNT software
- measured values displayed directly on the suspension cables, can be hidden if required

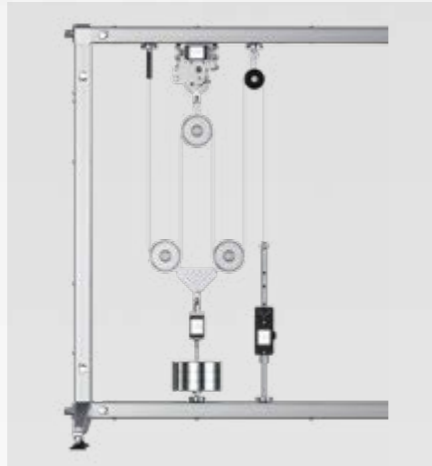

2 Calculation of cable forces and support forces

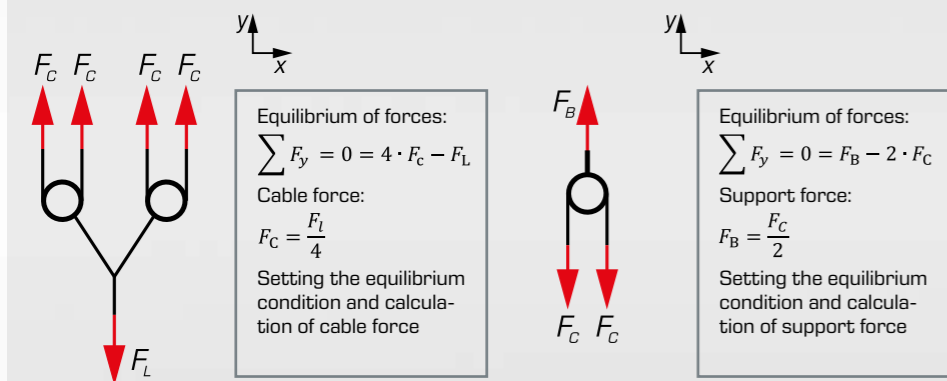

3 Checking the calculation: comparison of results with the measured values on suspension cable/supports and the results from the GUNT software

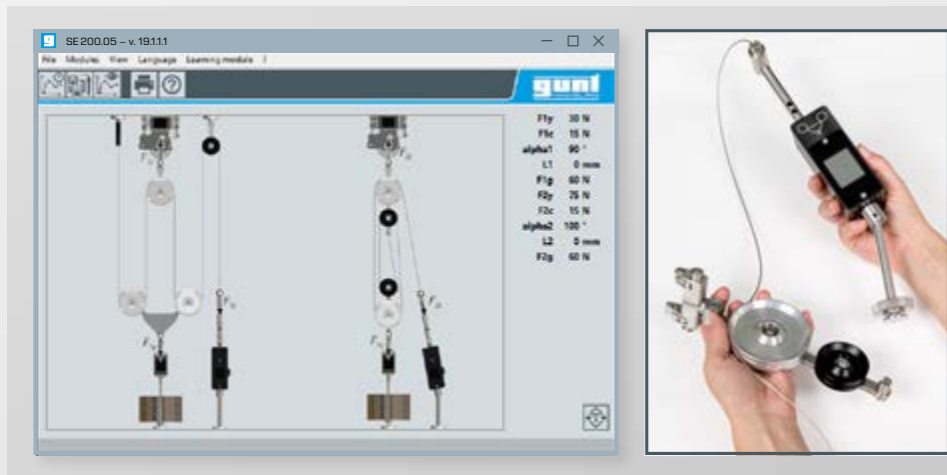

- smart, communication-enabled suspension cables with electronic modules for data acquisition and measured value display
- investigate 2 different pulley blocks at the same time
- 2 setup variants possible per pulley block
- automatic identification and assignment of the pulley blocks in the GUNT software

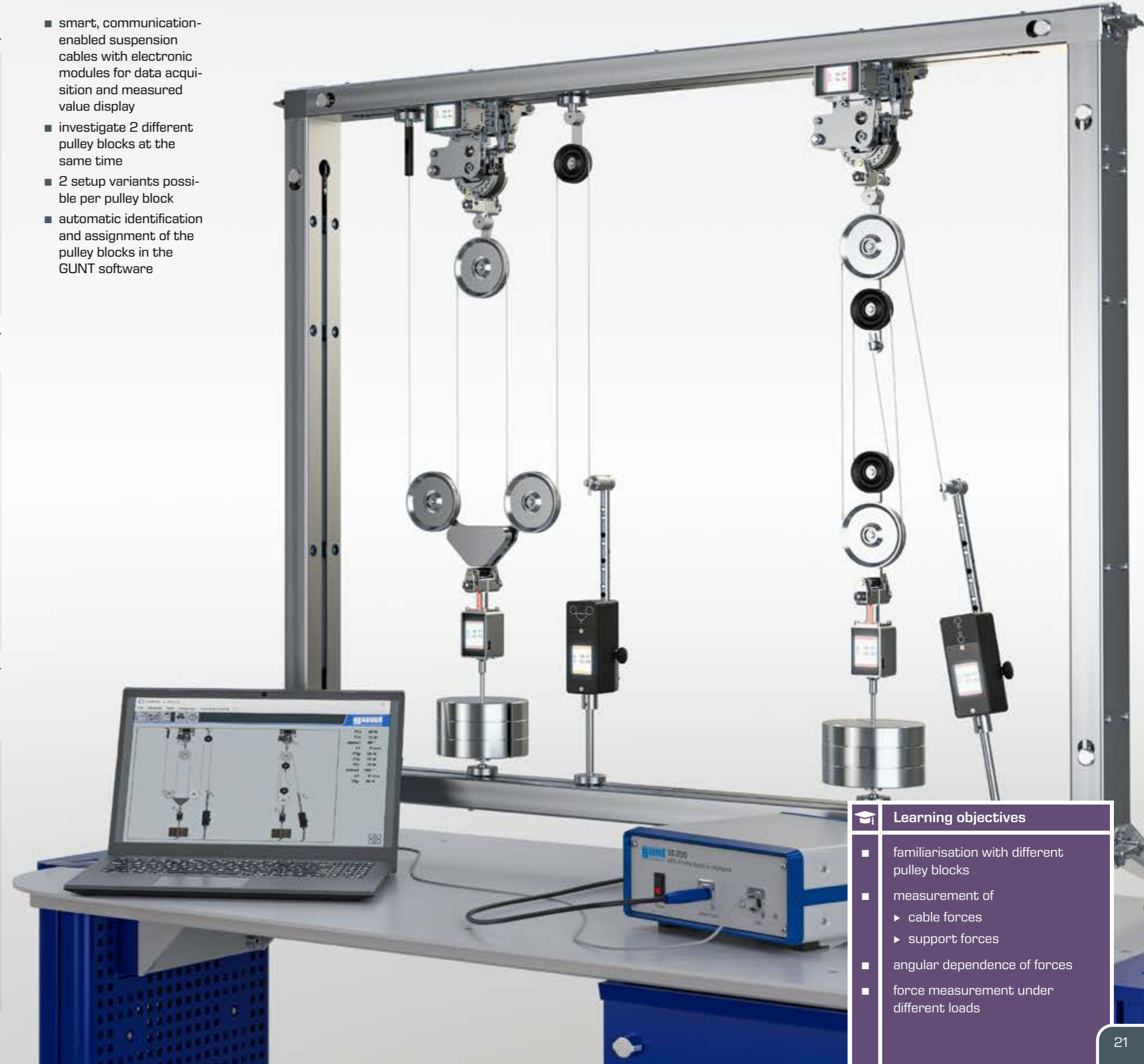

### Learning objectives

- familiarisation with different pulley blocks
- measurement of
  - ▶ cable forces
  - ▶ support forces
- angular dependence of forces
- force measurement under different loads

# SE 200.07 MEC – Gerber beam

## Exercises

- 1 Setup of a bridge consisting of a statically determined Gerber beam with different loads. Development of a simplified sketch for the system. Set up the equilibrium conditions.

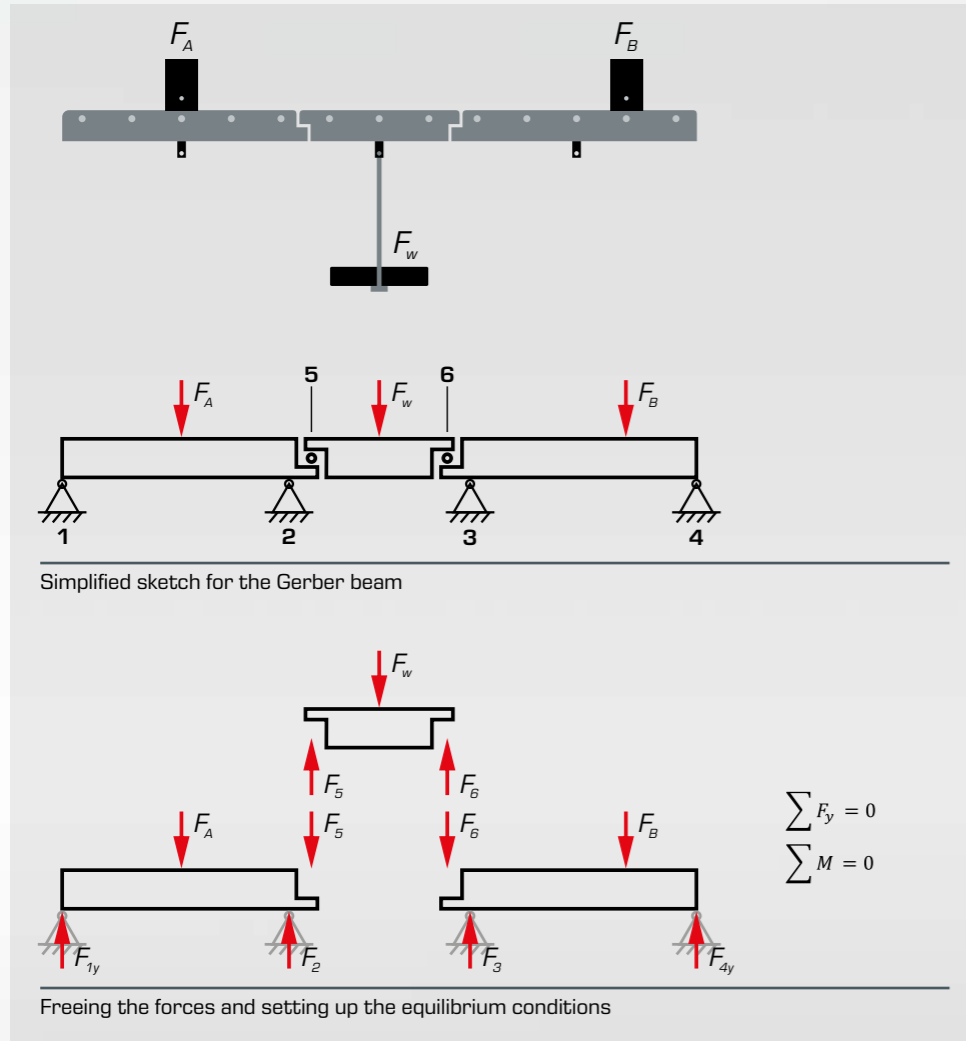

- 2 Experimental setup with a moving load on the roadway. Evaluation of the corresponding influence lines.

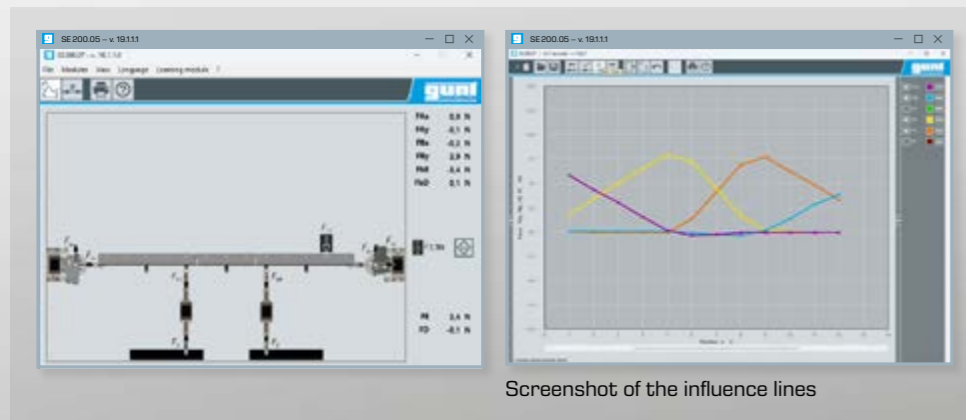

- investigation of the lines of influence in the statically determinate Gerber beam
- loading of the beam with optional individual loads (including as moving load), line load, vertical load
- automatic identification and exact position detection of the loads on the roadway using a binary code (Gray code)
- display of the measured values and visual representation of the forces in the GUNT software



**Learning objectives**

- application of the method of sections and the conditions of equilibrium in statics for calculating the support forces
- determination of internal reactions under static load
- determine lines of influence under moving load
- comparison of calculated and measured support reactions for static load and moving load

# SE 200.08 MEC – Buckling

- measurement of buckling forces and deflections on test bars for all 4 Euler cases
- high transmission ratio for a wide range of experiments (1:10)
- different types of support for test bars: free, hinged and clamped
- automatic identification and assignment of accessories during setup and while conducting the experiment

## Buckling length dependent on the support conditions of the test bars

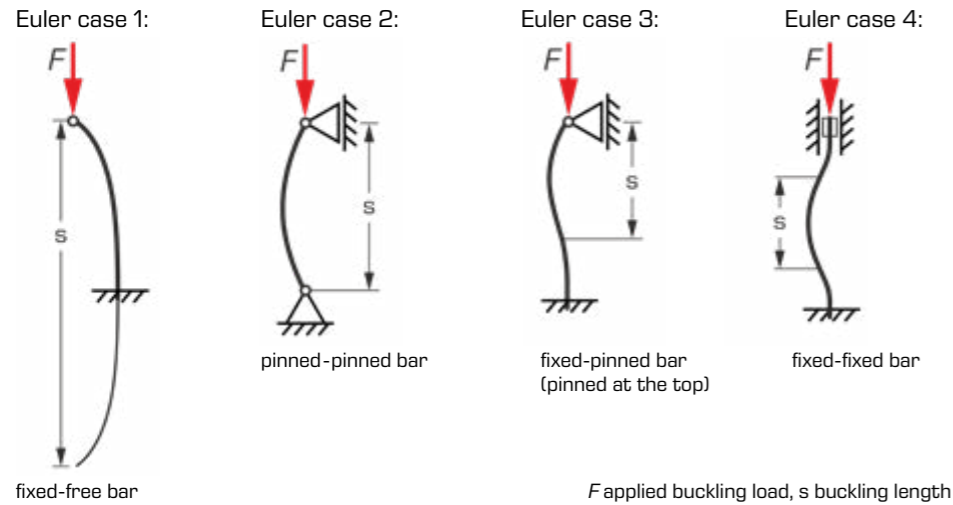

Euler case 3: bar fixed at the top, pinned at the bottom; the buckling of the test bar is measured



## Exercise

- 1 The deflection (deformation) of the test bar is measured. A force-deformation diagram is to be created from these measured values and compared with the values from the buckling theory.

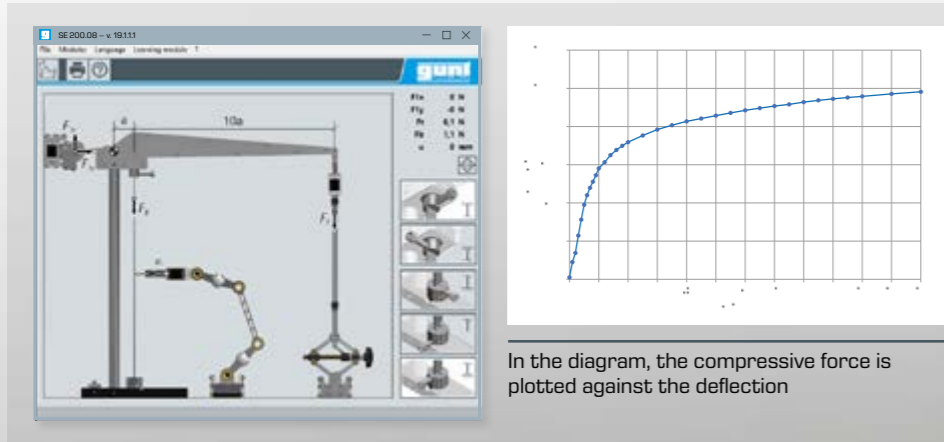

- Lerninhalte**
- investigation of buckling behaviour under the influence of different bearings
  - verification of the Euler theory: buckling of elastic bars
  - calculation of the expected buckling force using the Euler formulae
  - measure force and deflection

# GUNT Science Media Center

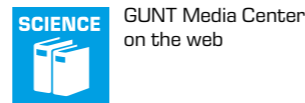
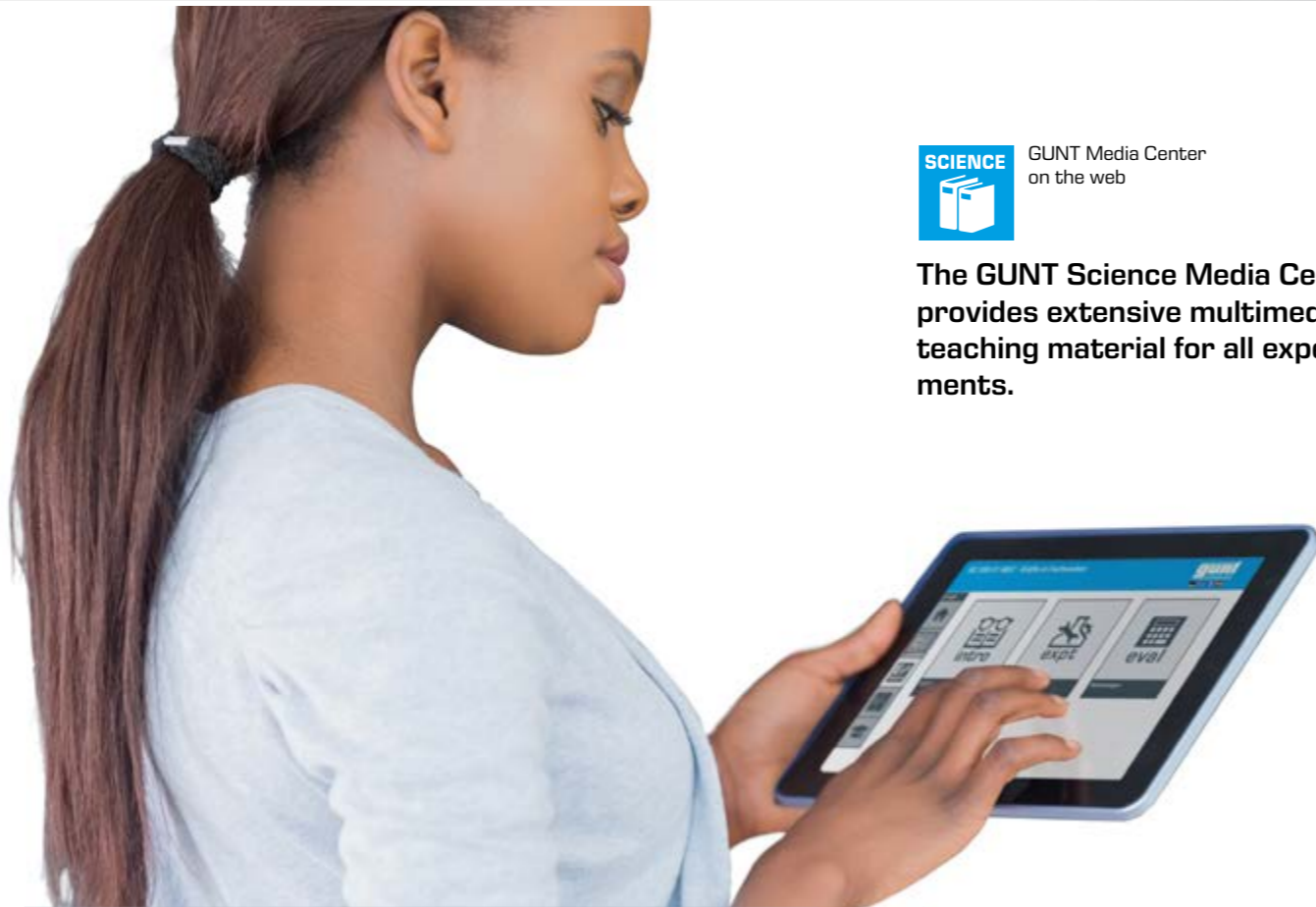

The GUNT Science Media Center provides extensive multimedia teaching material for all experiments.

Customers can access files and product information for selected products at any time and from any place. In addition to digital worksheets and the manual, access to E-Learning is also included.



## The E-Learning course

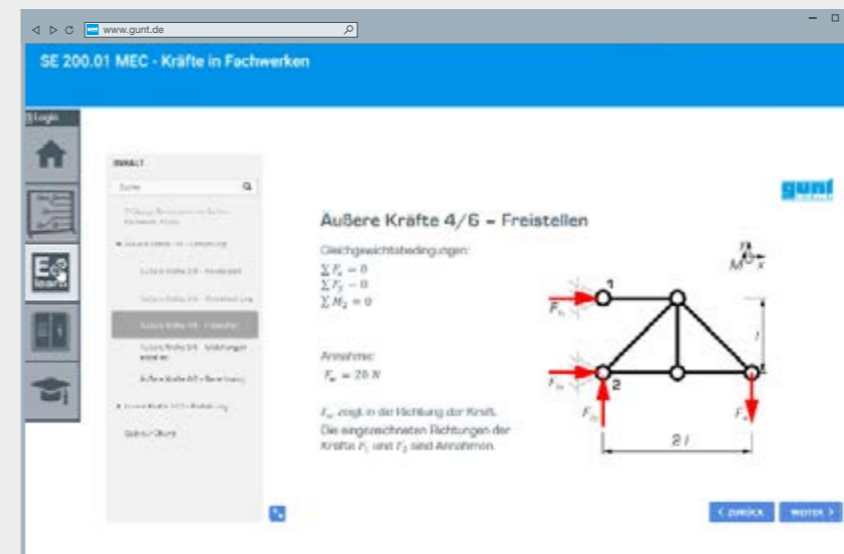

The E-Learning course presents fundamental knowledge and the experiment procedure in detail with engaging animations. Knowledge tests facilitate understanding.

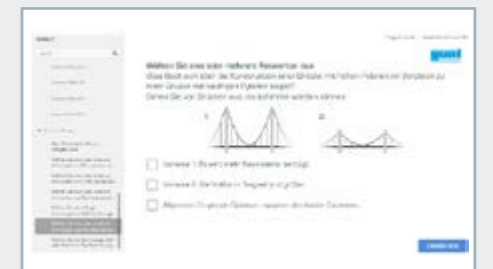

## Digital worksheets

Digital worksheets are available for the individual experiments. Access to solutions is password protected.

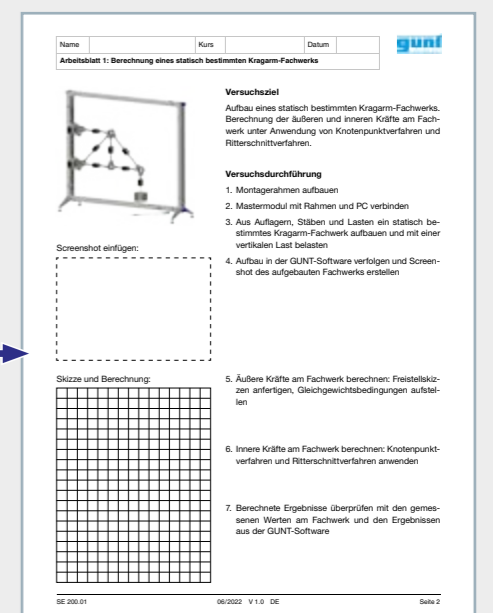
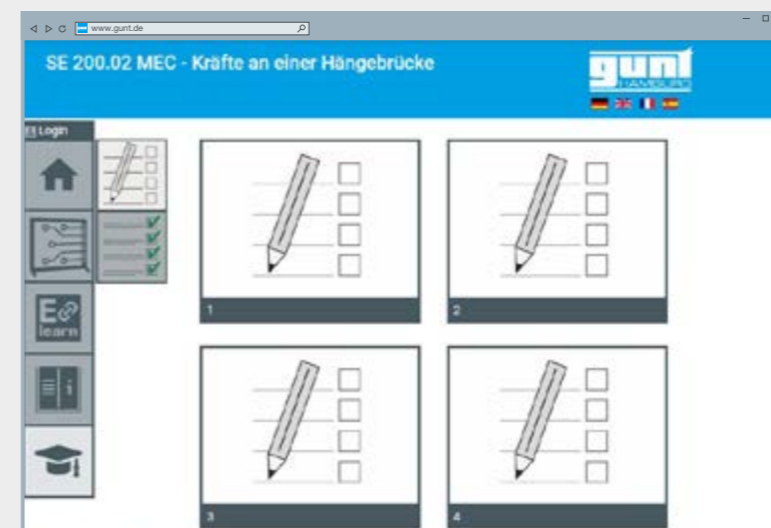



# Contact

G.U.N.T. Gerätebau GmbH  
Hanskampring 15-17  
22885 Barsbüttel  
Germany

+49 40 67 08 54 - 0  
sales@gunt.de  
www.gunt.de



Visit our website  
[www.gunt.de](http://www.gunt.de)

